

**HUAHUA** 桦桦数控®

**GUANGDONG SHUNDE CHANGSHENG  
MACHINERY MANUFACTURING CO., LTD.**

**Company Profile**

Website: [www.huahuacnc.com](http://www.huahuacnc.com)

**CATALOG**

01



**ENTERPRISE  
OVERVIEW**

02



**STRATEGIC  
COOPERATION**

03



**TECHNOLOGICAL  
INNOVATION**

04



**PRODUCT  
SYSTEM**

05



**CUSTOMER  
CASE**

06



**SERVICE  
SYSTEM**



# 01-ENTERPRISE OVERVIEW

- Enterprise Strength
- Qualification & Honor

**70,000**<sub>m<sup>2</sup></sub> *Production area* **New**

*The total area of Leliu Base*

## GUANGDONG SHUNDE CHANGSHENG MACHINERY MANUFACTURING CO., LTD.

- Located In Lunjiao, Shunde, An Important Woodworking Machinery Town In China, The Company's Predecessor, Huahua Machinery Factory, Was Founded In June 2003. With The Efforts Of All Staffs In The Company, The Products Have Been Continuously Improved And The Company Has Grown Stronger. After Factory Research, It Was Decided To Reorganize In September 2009. For Guangdong Shunde Changsheng Machinery Manufacturing Co., Ltd., The Brand "**HUAHUA MACHINERY**" Was Established In The Same Year.
- The Company Integrates Advanced Technology And Experience From China And Abroad, And Integrates Product Development, Design, Production, Sales And Service.the Main Products Are Computer Beam Saw, Cnc Router Machine, Edge Banding Machine, Cnc Drilling Machine, Etc. Continuously Develop And Innovate, Take Technology As The Core, Regard Quality As Life, And Take Customers As God, We Wholeheartedly Provide You With Cost-effective High-quality Advanced Products And Enthusiastic Professional Technical Consultation And Pre-sale, In-sale And After-sale Services.



CNC router machine workshop

精准开料车间



Computer beam saw workshop

高速裁板车间



Edge bonding machine workshop

自动封边车间



CNC drilling machine workshop

数控钻铣车间



Automatic machines line workshop

自动化车间



ENTERPRISE OVERVIEW  
COMPANY PROFILE

**HUAHUA** 桦桦数控®



**35,000**<sup>m<sup>2</sup></sup> *Production area* **Current**

## GUANGDONG SHUNDE CHANGSHENG MACHINERY MANUFACTURING CO., LTD.

- Located In Lunjiao, Shunde, An Important Woodworking Machinery Town In China, The Company's Predecessor, Huahua Machinery Factory, Was Founded In June 2003. With The Efforts Of All Staffs In The Company, The Products Have Been Continuously Improved And The Company Has Grown Stronger. After Factory Research, It Was Decided To Reorganize In September 2009. For Guangdong Shunde Changsheng Machinery Manufacturing Co., Ltd., The Brand "**HUAHUA MACHINERY**" Was Established In The Same Year.
- The Company Integrates Advanced Technology And Experience From China And Abroad, And Integrates Product Development, Design, Production, Sales And Service.the Main Products Are Computer Beam Saw, Cnc Router Machine, Edge Banding Machine, Cnc Drilling Machine, Etc. Continuously Develop And Innovate, Take Technology As The Core, Regard Quality As Life, And Take Customers As God, We Wholeheartedly Provide You With Cost-effective High-quality Advanced Products And Enthusiastic Professional Technical Consultation And Pre-sale, In-sale And After-sale Services.





**20000**<sub>m<sup>2</sup></sub> *Jiangmen welding and processing workshop*

## Guangdong Shunde Changsheng Machinery Manufacturing Co. LTD

In 2021 in response to the company's output expansion, while strengthening the internal quality, has gradually implemented in Jiangmen 20000 square meters of industrial plant for **welding, annealing, processing and powder spraying one of the efficient processing workshop**, and the purchase of multiple high-precision Longmen CNC to improve the overall high-precision processing capacity.

We Have **More Than 300** Employees



# ENTERPRISE OVERVIEW

## COMPANY PROFILE

**HUAHUA** 桦桦数控®



Computer Beam Saw Workshop



Cnc Router Machine Workshop



Edge Banding Machine Workshop



CNC Drilling Machine Workshop

## Automated Production Line Workshop

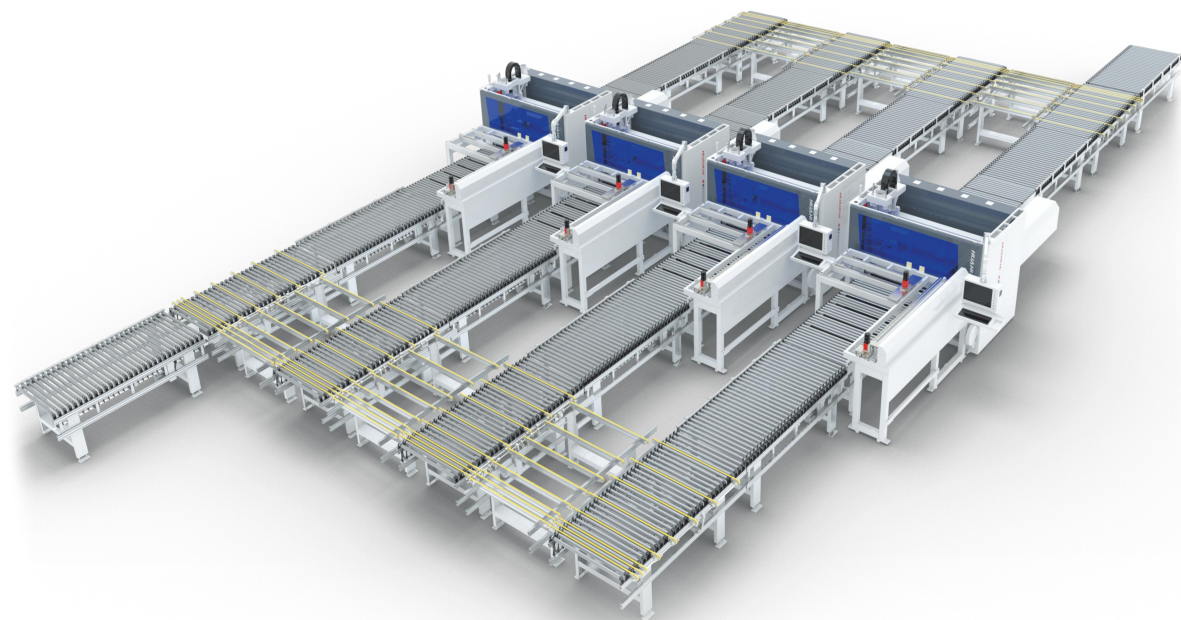

# ENTERPRISE STRENGTH DEVELOPMENT HISTORY

**HUAHUA** 桦桦数控®

**2003-2012**

Changsheng Machinery  
Was Founded,  
Ten Years Of Market  
Development

**2013**

Computer Beam Saw  
Mass Production And  
Marketization

**2015**

Five-sided Drill Mass  
Production  
Six-sided Drill Research  
And Development

**2016**

Started Produce Edge  
Banding Machine Series  
And Cnc Router Machine  
Series

**2017**

Improve Four Product  
Series And Panel  
Furniture Production Line

since **2003**

**22** Development History  
years

**2025-Future**

Digital And Intelligent  
Further Development

**2021**

Brand Building  
Five major product  
series upgrades

**2020**

In Depth Plant Planning  
And Automation System

**2019**

A9 Unmanned  
Automatic  
Production Line

**2018**

Whole Plant Planning  
And Automation System

## We Have Mature R&D Team



## We Have Rigorous QC Team



The Working Principle Of the QC Department  
"Customer First, Quality First!"

QC: IQC——PQC——OQC

We Have Professional **Sales Team**



We Have Professional **After-sales Service Team**



“Honors”



“Honors”



# 02-PARTNERSHIP

- Domestic Market
- Oversea Market

5000+ Domestic Customers

尚品宅配  
全屋家具 科技定制

PIANO  
皮阿诺 橱柜·衣柜

HOLIKE®  
好莱客

WAYES  
维意定制

顶固®  
TOPSTRONG  
衣柜·滑动门·生态门

OLO 我乐  
整体橱柜 | 全屋定制

lòmg  
蓝谷·智能厨房

ARROW  
箭牌衣柜

鼎派世家  
DING PAI SHI JIA

德夫曼® 衣柜  
德品质 夫责任 曼步调

PAIRIE 柏莱雅

中至信家具  
ZHONGZHIXIN FURNITURE

yadan 亚丹

德维尔衣柜

ZH  
志华集团  
ZHIHUA GROUP  
志于至善·华饰生活

嘉燕斯  
全屋家具定制

TATA 木门

华朗图

LOVICA®  
诺维家  
— 皇家软装世家 —

ds  
慕思寝具

HANEX  
韩丽橱柜

壹家壹品

日丰卫浴

联邦 L

S  
斯高家具  
SOCO LIFE

zbom  
志邦厨柜

WISION  
维尚家具

伊仕利家居  
E-home

富森木业  
Fusen Wood

DNIMAY 丹尼曼  
— 全 | 屋 | 定 | 制 —

兴利万家  
Hing Lee Myriad Home

AUMDI 欧曼迪  
— 打造亿家时尚健康厨房 —

伊美嘉™

ONMUSE®  
— 欧美斯 —

九凤 木门

TUBAO 兔宝宝

MB  
美邦家纺

RED APPLE | 红苹果

多伦斯衣柜  
TOLONS

RelyBest  
伊莱·贝斯特

中哈定制  
ZHONGHADINGZHI

AIEGLE  
艾依格衣柜

KLONI  
克洛尼橱柜

AIGER  
爱格工房

JONGTAY  
中泰办公家具

Export to **50+** Countries



America  
美国



Australia  
澳大利亚



Azerbaijan  
阿塞拜疆



Arab Emirates  
阿联酋



Algeria  
阿尔及利亚



Argentina  
阿根廷



Armenia  
亚美尼亚



Bulgaria  
保加利亚



Bolivia  
玻利维亚



Brasil  
巴西



Bangladesh  
孟加拉国



Chile  
智利



Canada  
加拿大



Columbia  
哥伦比亚



Cambodia  
柬埔寨



Egypt  
埃及



Ecuador  
厄瓜多尔



Ethiopia  
埃塞俄比亚



Germany  
德国



Italy  
意大利



Iraq  
伊拉克



Ireland  
英国



India  
印度



Iran  
伊朗



Indonesia  
印度尼西亚



Jordan  
约旦



Korea  
韩国



Kenya  
肯尼亚



Kosovo  
科索沃



Kazakhstan  
哈萨克斯坦



Lebanon  
黎巴嫩



Libya  
利比亚



Lithuania  
立陶宛



Lesotho  
莱索托



Mauritius  
毛里求斯



Macedonia  
马其顿



Myanmar  
缅甸



Morocco  
摩洛哥



Mexico  
墨西哥



Malaysia  
马来西亚



Nepal  
尼泊尔



Nigeria  
尼日利亚



Pakistan  
巴基斯坦



Palestine  
巴勒斯坦



Peru  
秘鲁



Philippines  
菲律宾



Polska  
波兰



Qatar  
卡塔尔



Romania  
罗马尼亚



Russia  
俄罗斯



Saudi Arabia  
沙特阿拉伯



Syria  
叙利亚



South Africa  
南非



Spain  
西班牙



Singapore  
新加坡



Thailand  
泰国



Turkey  
土耳其



Uzbekistan  
乌兹别克斯坦



Ukraine  
乌克兰



Vietnam  
越南

# 03-TECHNICAL INNOVATION

- Patent certificate
- Scientific research achievements

# TECHNICAL INNOVATION PATENT CERTIFICATE

65 Utility Models  
ITEMS

7 Design Patent  
ITEMS

4 High-tech Products  
ITEMS

2 Invention Patent  
ITEMS

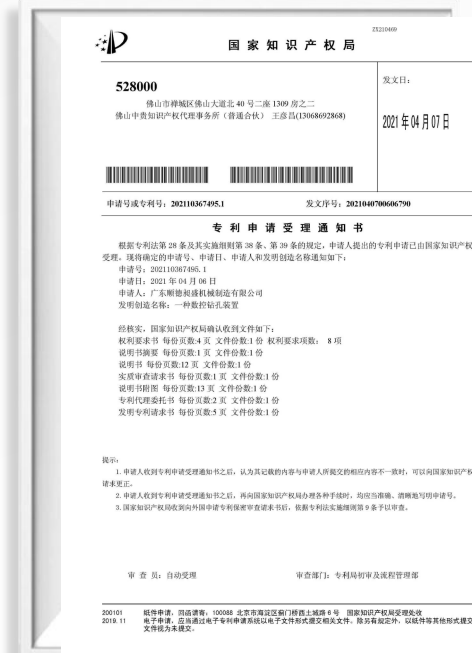

# ISO AND CE CERTIFICAT

**ISO** quality management system  
certification

EU CE Certification  
**4** ITEMS





## The Cooperative Education Base of Wu Yi University

- The company has established strategic cooperation with Jiangmen Wuyi University,
- The two sides jointly build an industry-university-research platform, provide training and practice bases for new students.

# 04-PRODUCT SYSTEMS

- **CNC Router Machine**
- **Computer Beam Saw**
- **Automatic Edge Banding Machine**
- **CNC Drilling Machine**
- **Intelligent Production Line**

Drilling and cutting integrated machine

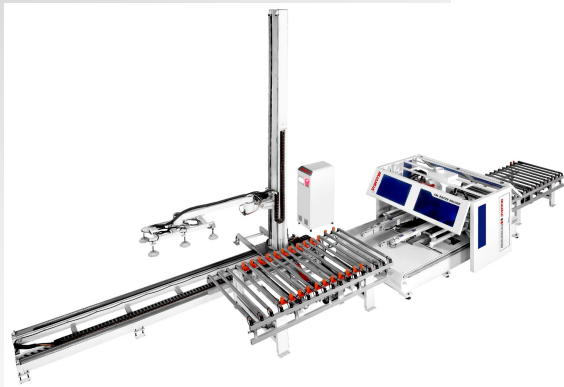
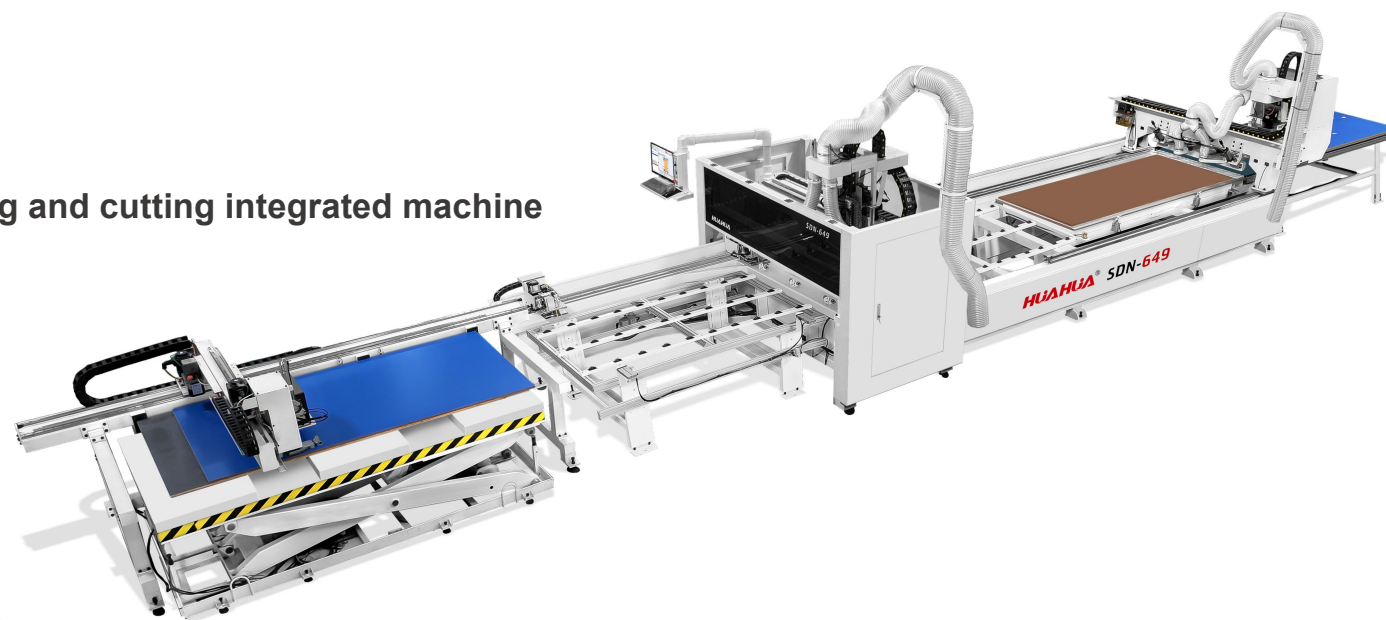

Four sided saw

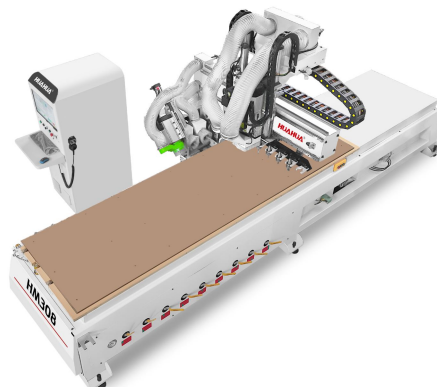

Door wall cabinet integrated machine



Automatic linear type Tool Change Series



PRODUCT SYSTEM  
CNC ROUTER MACHINE CLASSIFICATION

HUAHUA 桦桦数控®

01

Automatic disc type Tool Change Series



02

Automatic linear type Tool Change Series



03

CNC Router Machine with drill pack Series



04

Automatic Loading and Unloading Series



05

Automatic Labeling Machine



CNC ROUTER  
MACHINE  
CLASSIFICATION

2 Sets Cnc Router Machine  
Line With Robot

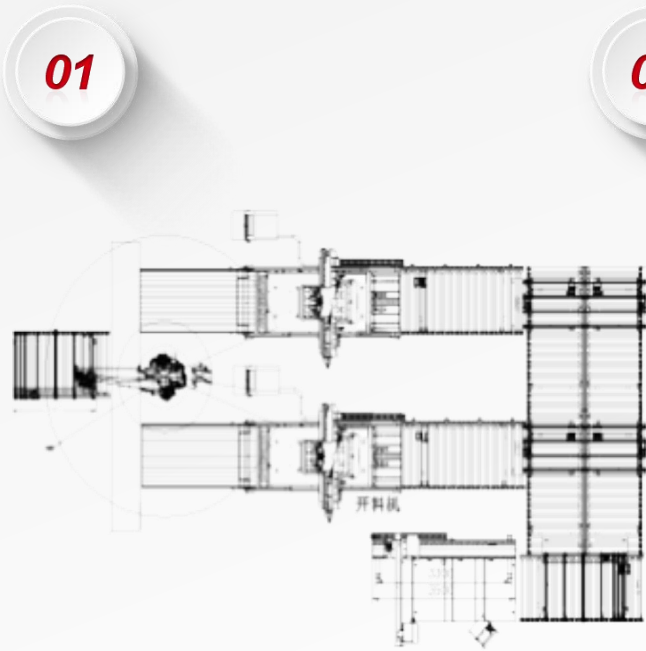

4 Sets Cnc Router  
Machine Line

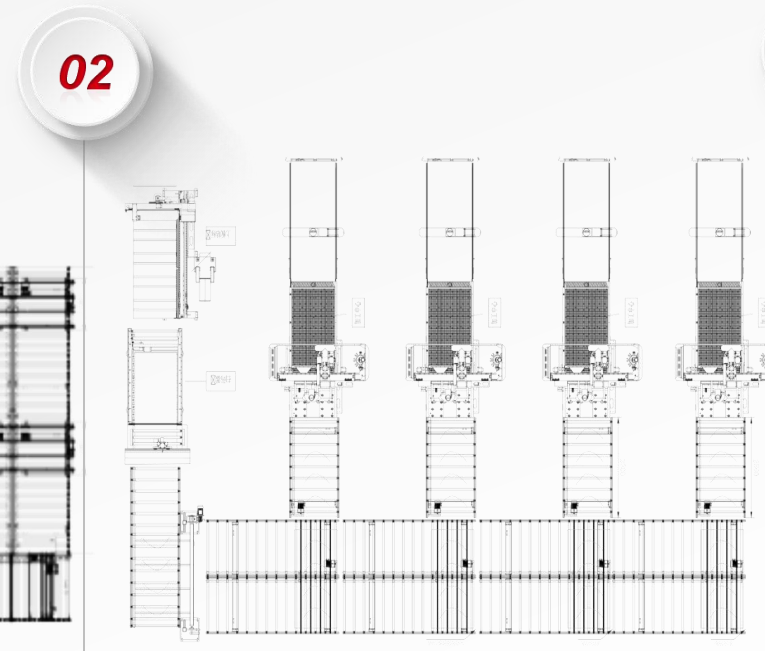

6 Sets Cnc Router Machine  
Line with Robot

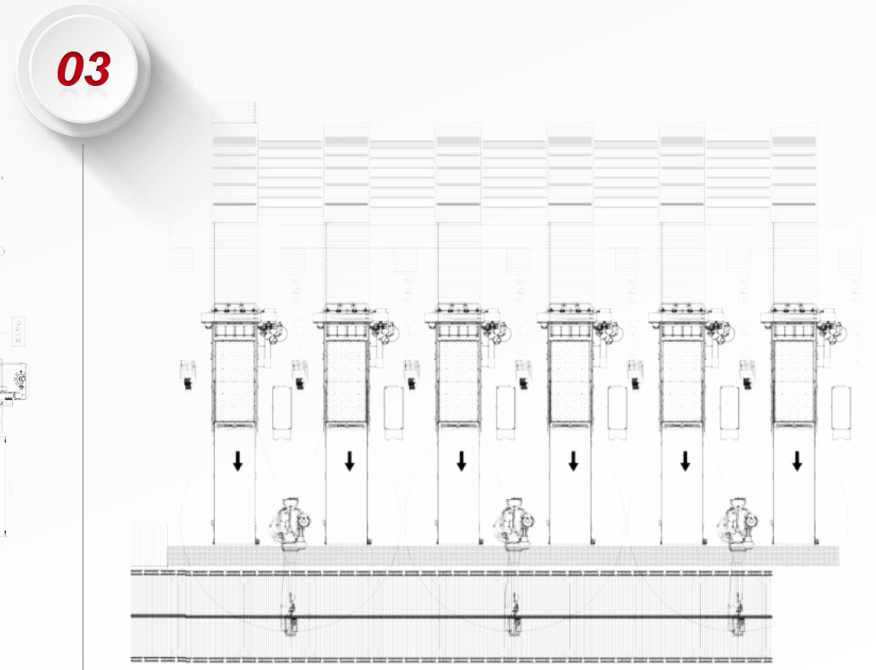

# PRODUCT SYSTEMS

## COMPUTER BEAM SAW CLASSIFICATION

**HUAHUA** 桦桦数控®

01

Computer Angular Saw Series



02

Double push hand computer beam saw



COMPUTER  
BEAM SAW  
CLASSIFICATION

03

Rear Loading Series



04

HP Series



Front Feeding Scheme of  
Computer Beam Saw

Rear Feeding Scheme of  
Computer Beam Saw

3 Sets Computer Beam  
Saw Line

01

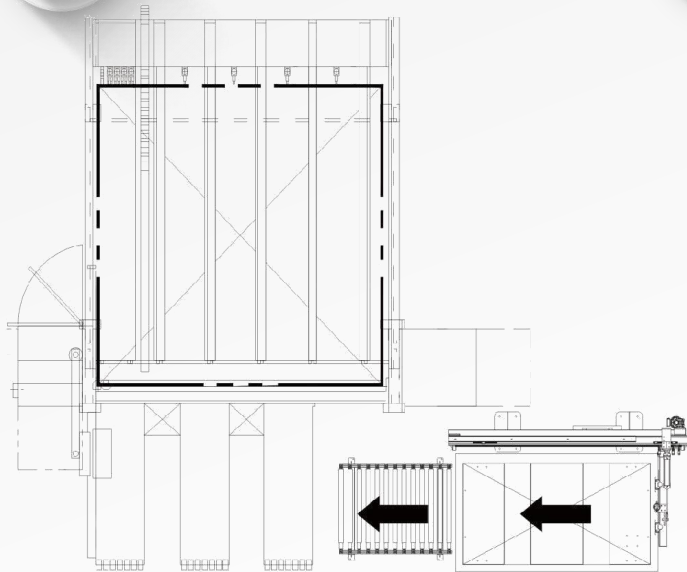

02

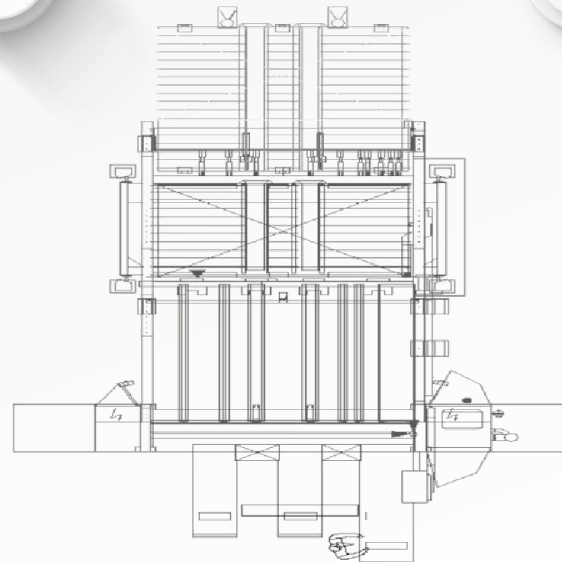

03

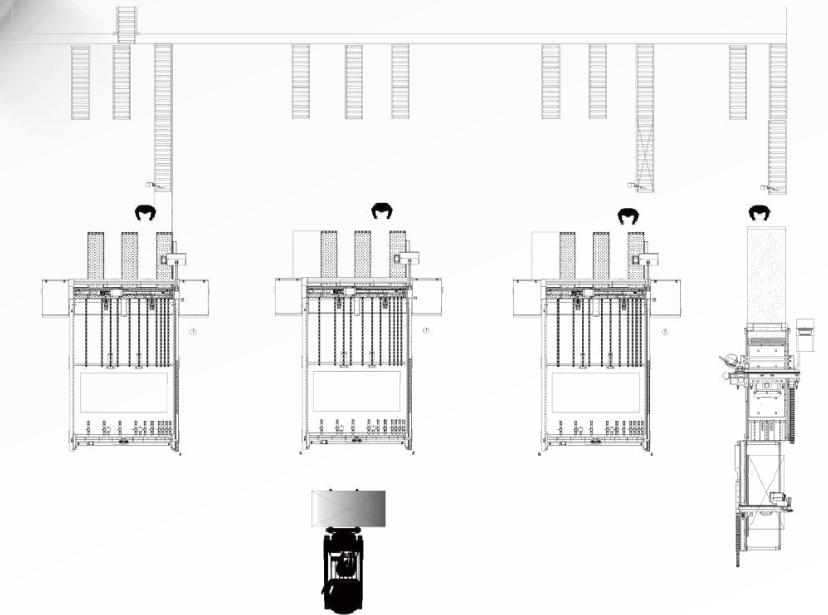

PRODUCT SYSTEMS  
AUTOMATIC EDGE BANDING MACHINE CLASSIFICATION

HUAHUA 桦桦数控®

01

Double-side Edge Banding Machine Series



03

High-speed Edge Banding Machine Series

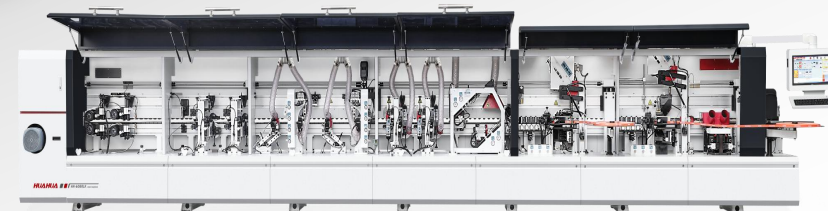

02

Inclined And Straight Edge Banding Machine Series

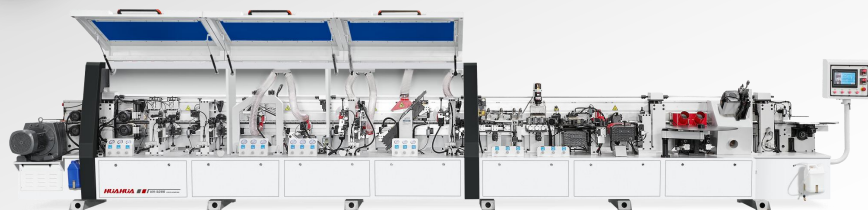

AUTOMATIC EDGE  
BANDING MACHINE  
CLASSIFICATION

04

General Edge Banding Machine

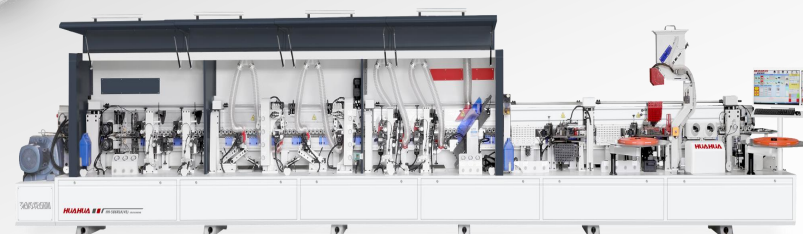

# AUTOMATIC **SERVO** EDGE BANDING MACHINE

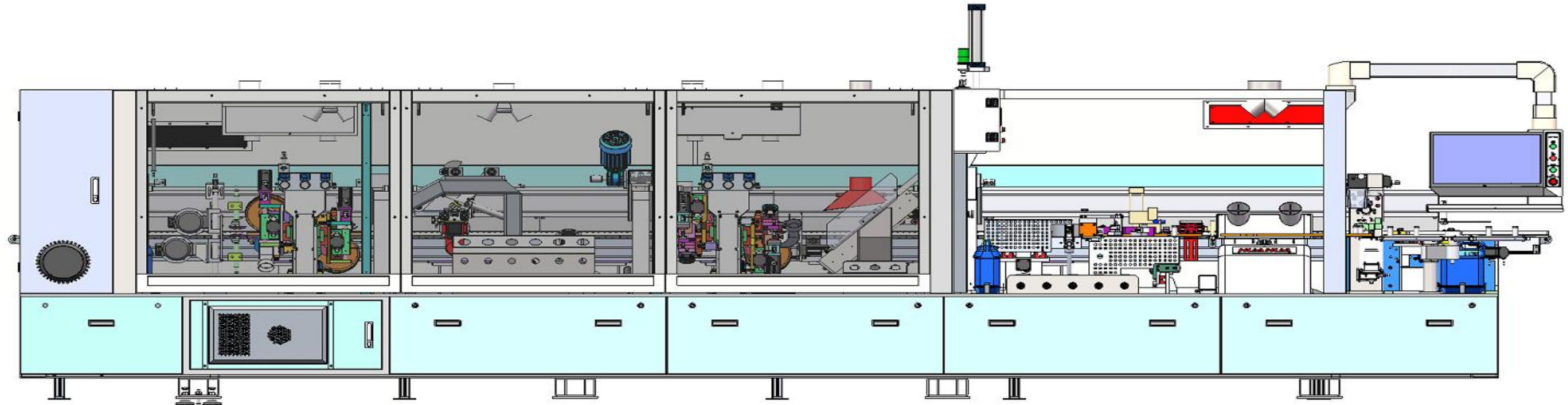

# AUTOMATIC **LASER** EDGE BANDING MACHINE

01

Laser edge banding machine



02

High speed laser edge banding machine



- High aesthetics: The board and the edge banding are perfectly combined, basically leaving no seam lines
- Environmental protection and health: no glue is needed to avoid potential harm to the human body
- High sealing degree: it can effectively prevent water vapor from entering and ensure the service life of furniture
- High production efficiency: fewer processes, one-time edge banding, improving product qualification rate

01

Left And Right Edge Banding  
Machine Line

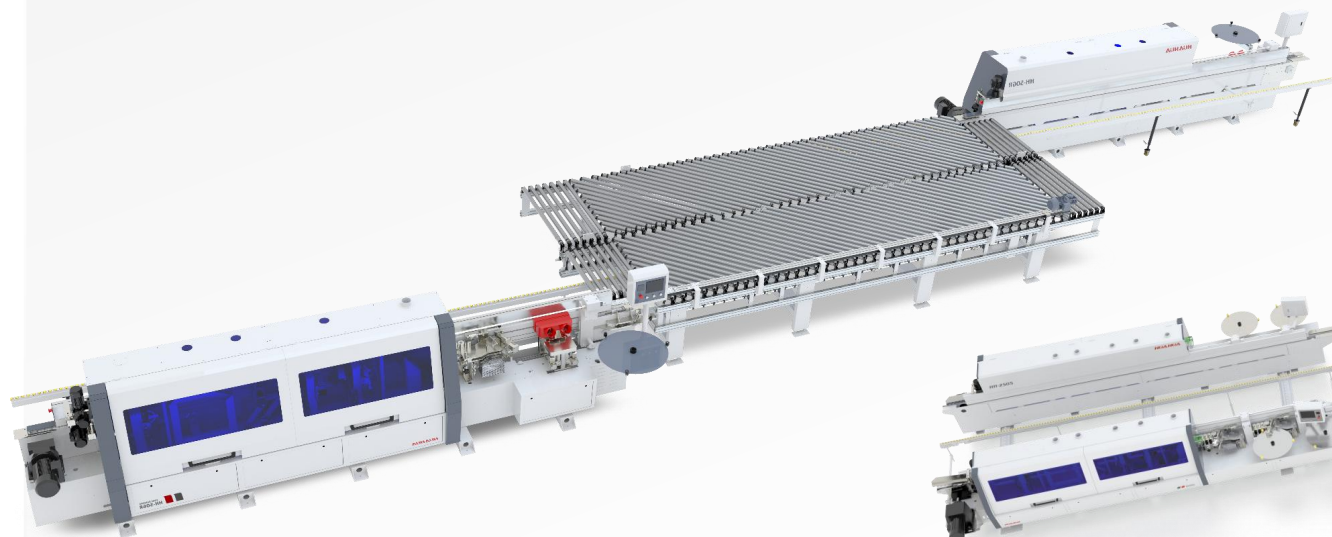

02

Four Sides Edge Banding  
Machine Line

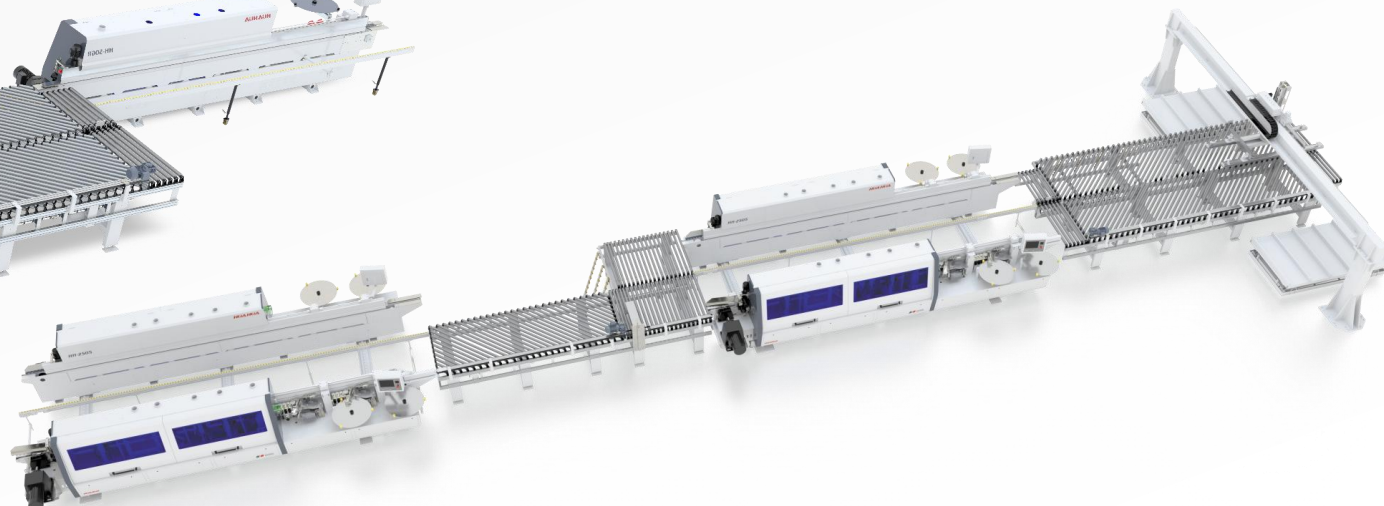

PRODUCT SYSTEMS  
CNC DRILLING MACHINE CLASSIFICATION

01

Six Sides Cnc Drilling Machine Series



02

Automatic drilling machine line



03

Automatic drilling machine

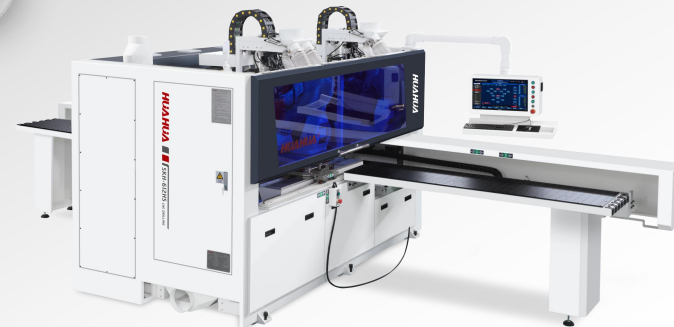

04

CNC Full Servo Drilling Machine Series



05

Multi-spindle Drilling Machine Series



CNC DRILLING  
MACHINE  
CLASSIFICATION

4 Sets Cnc Drilling Machine Line

01

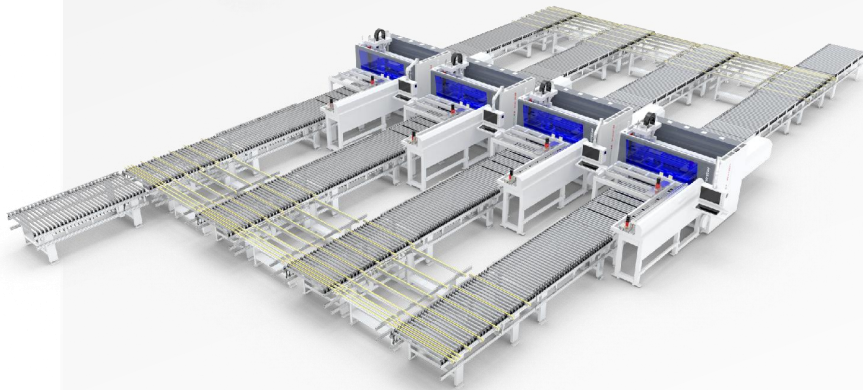

Automatic Four-rows  
Drilling Machine Line

02

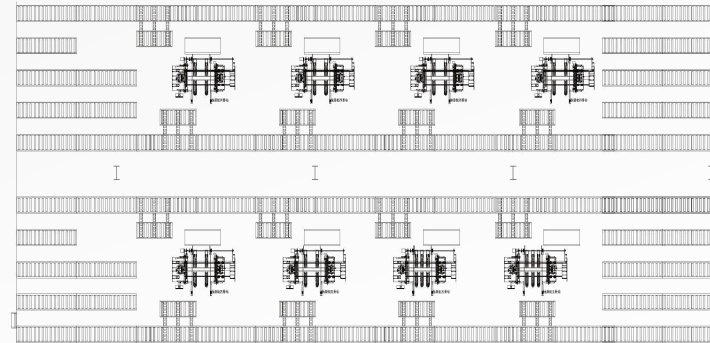

Automatic Six-rows  
Drilling Machine Line

03

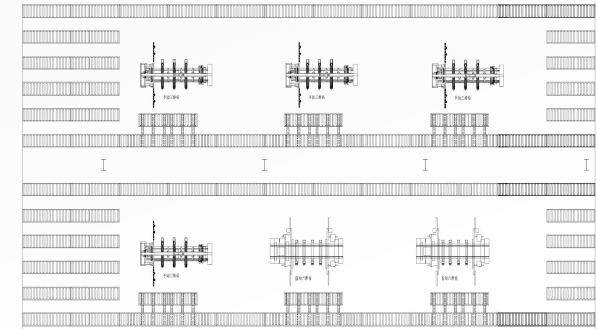

# 05-CUSTOMER CASE

- **Application**
- **Smart production line**
- **Customer case**

01

Panel Style Furniture



02

America Style Cabinet



03

Cabinet Industry



04

Bathroom Style



05

Wooden Door Industry



06

Full House Customization



PANEL STYLE AUTOMATIC PRODUCTION LINE PLAN A



4 Sets Cnc Router Machine With Automatic loading And Unloading Platform +4 Sets Edge Banding Machine Production Line +5 Sets Cnc Drilling Machine Production Line+Sorting

Output Capacity: 50 pcs board/hour    Floor Space: 2000m<sup>2</sup>    Power Waste: 380KW/hour

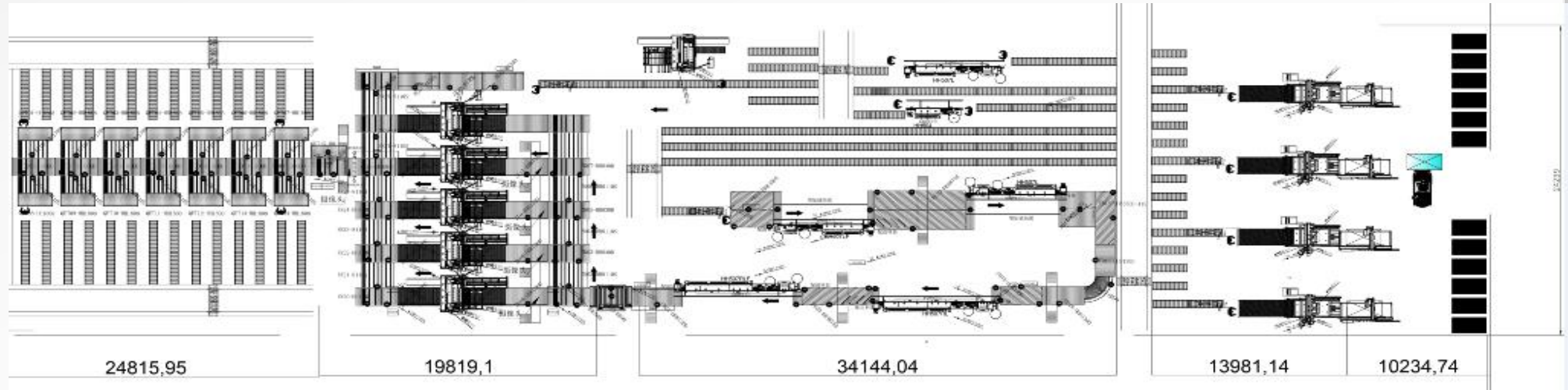



## DING PAI SHI JIE FACTORY CASE

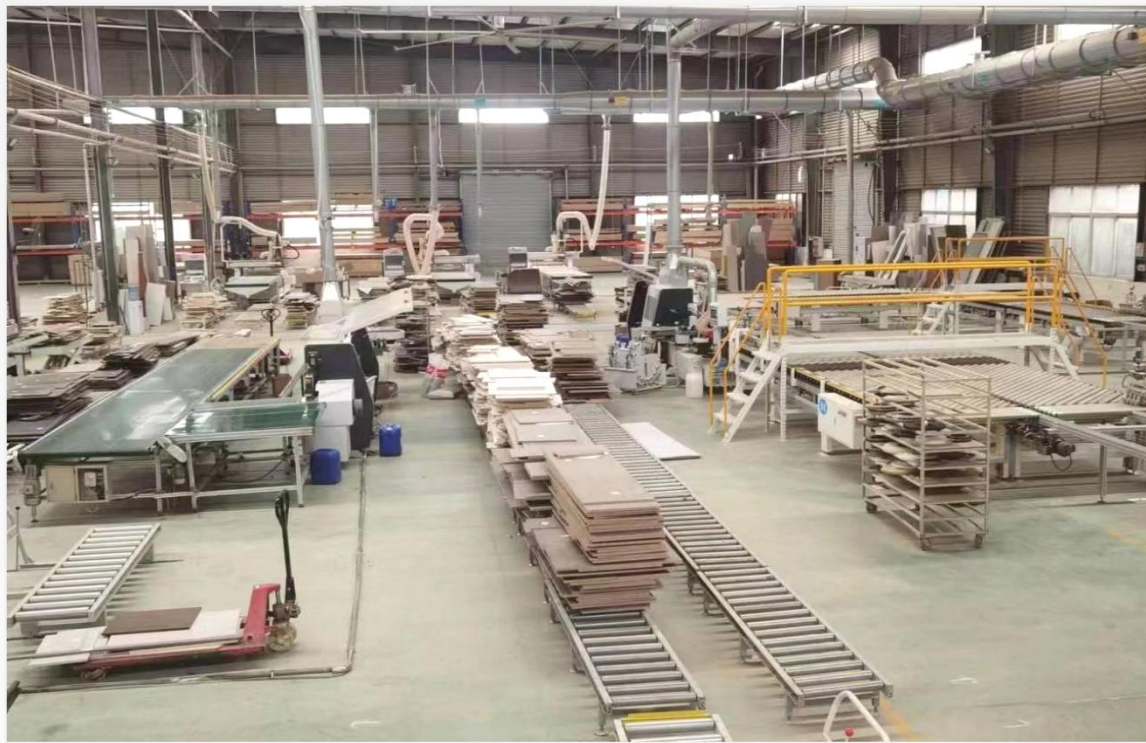

PANEL STYLE SMART PRODUCTION LINE PLAN B

华朗图

2 Sets Cnc Nesting Lines +left-right Side Edge Banding Machine Production Line

+3 Sets 6 Sided Cnc Drilling Machine Production Line+Sorting

Output Capacity: 25 pcs board/hour Floor Space: 2000m<sup>2</sup> Power Waste: 206KW/hour

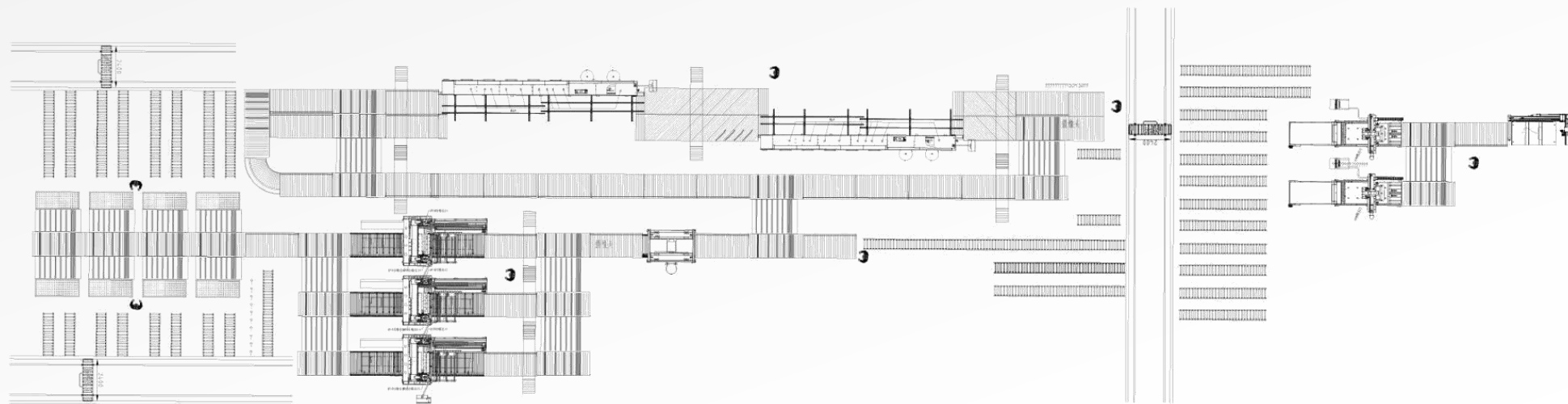

APPLICATION SYSTEM

PANEL STYLE AUTOMATIC PRODUCTION LINE PLAN D

HUAHUA 桦桦数控®

华朗图

HUANGLANGTU FACTORY CASE



PANEL STYLE SMART PRODUCTION LINE PLAN C

2 Sets Cnc Nesting Lines with Robot Arm+left-right Side Edge Banding Machine  
+2 Sets 6 Sided Cnc Drilling Machine Production Line

Output Capacity 20 pcs board/hour    Floor Space 1000m<sup>2</sup>    Power Waste: 180KW/hour

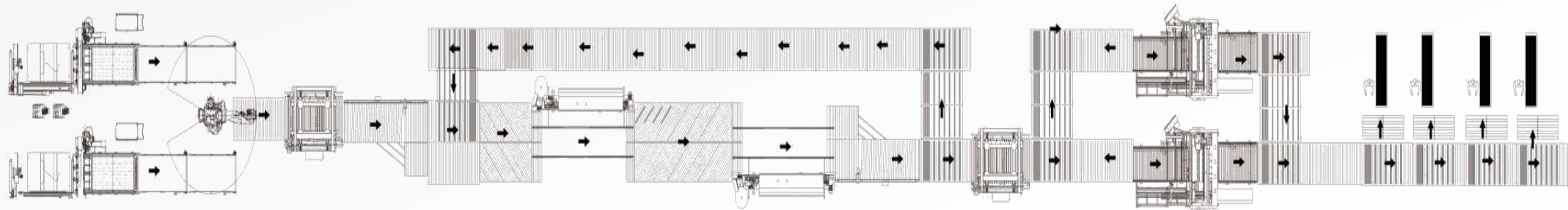

CHANGSHENG MACHINERY  
PANEL STYLE AUTOMATIC PRODUCTION LINE PLAN C

HUAHUA 桦桦数控®

WISION 维尚家具

WISION FACTORY CASE

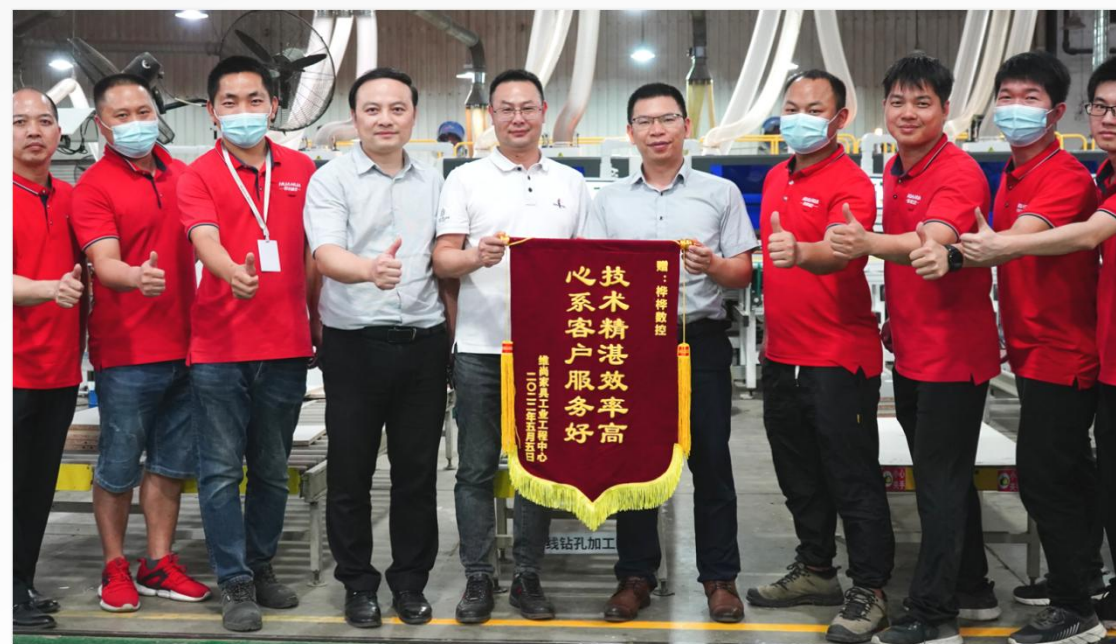

2 Sets Cnc Nesting Lines With Robot Arm+left-right Side Edge Banding Machine  
+3 Sets 6 Sided Cnc Drilling Machine Production Line

Output Capacity: 25 pcs board/hour Floor Space: 2000m<sup>2</sup> Power Waste: 190KW/hour

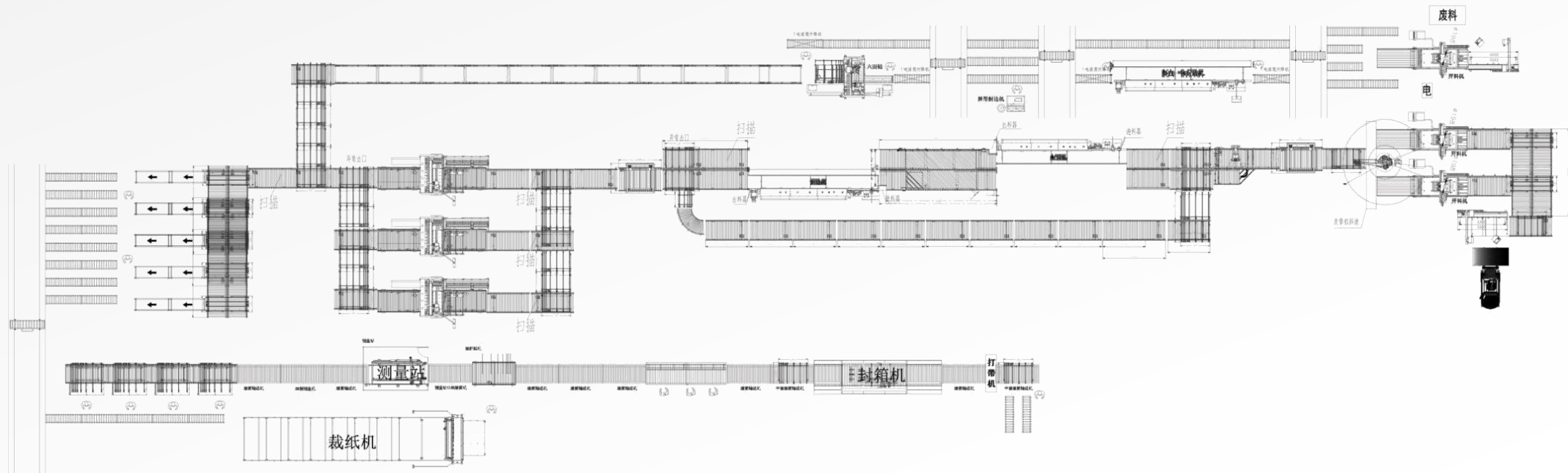

production lines in Thailand, Malaysia, Algeria, Saudi Arabia

**HUAHUA** 桦桦数控®



Malaysia Industrial Production Connection



Algeria production line



APPLICATION SYSTEM

PANEL STYLE AUTOMATIC PRODUCTION LINE PLAN D



HUAHUA 桦桦数控®

HOLIKE FACTORY CASE



掌上明珠

Master & Zest FACTORY CASE



CUSTOMER CASE

PANEL STYLE AUTOMATIC PRODUCTION LINE PLAN F

HUAHUA 桦桦数控®

SUNHOO

双虎家私FACTORY CASE



CUSTOMER CASE

PANEL STYLE AUTOMATIC PRODUCTION LINE PLAN G

HUAHUA 桦桦数控®



E'LIAN HOME  
伊恋全屋定制

伊恋家居FACTORY CASE



# 06-SERVICE

- DOMESTIC NETWORK
- SERVICE STANDARD

# SERVICE SYSTEM

## DOMESTIC SALES NETWORK



Domestic Sale Network covers To The Whole Chinese markets

50+

Deals Already Signed

60+



SERVICE SYSTEM  
EXHIBITION

HUAHUA 桦桦数控®

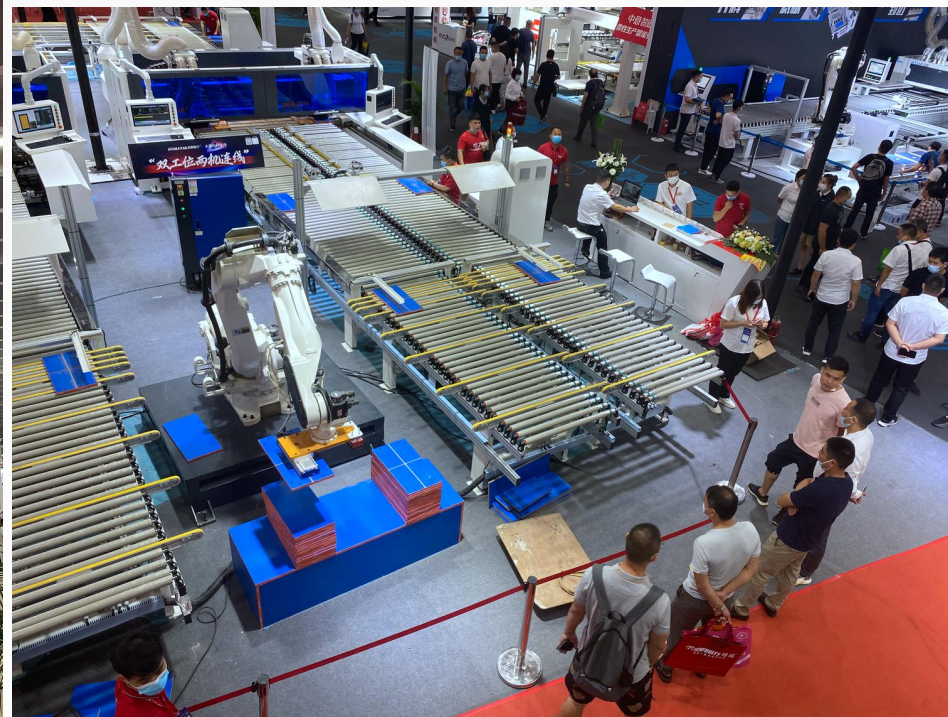
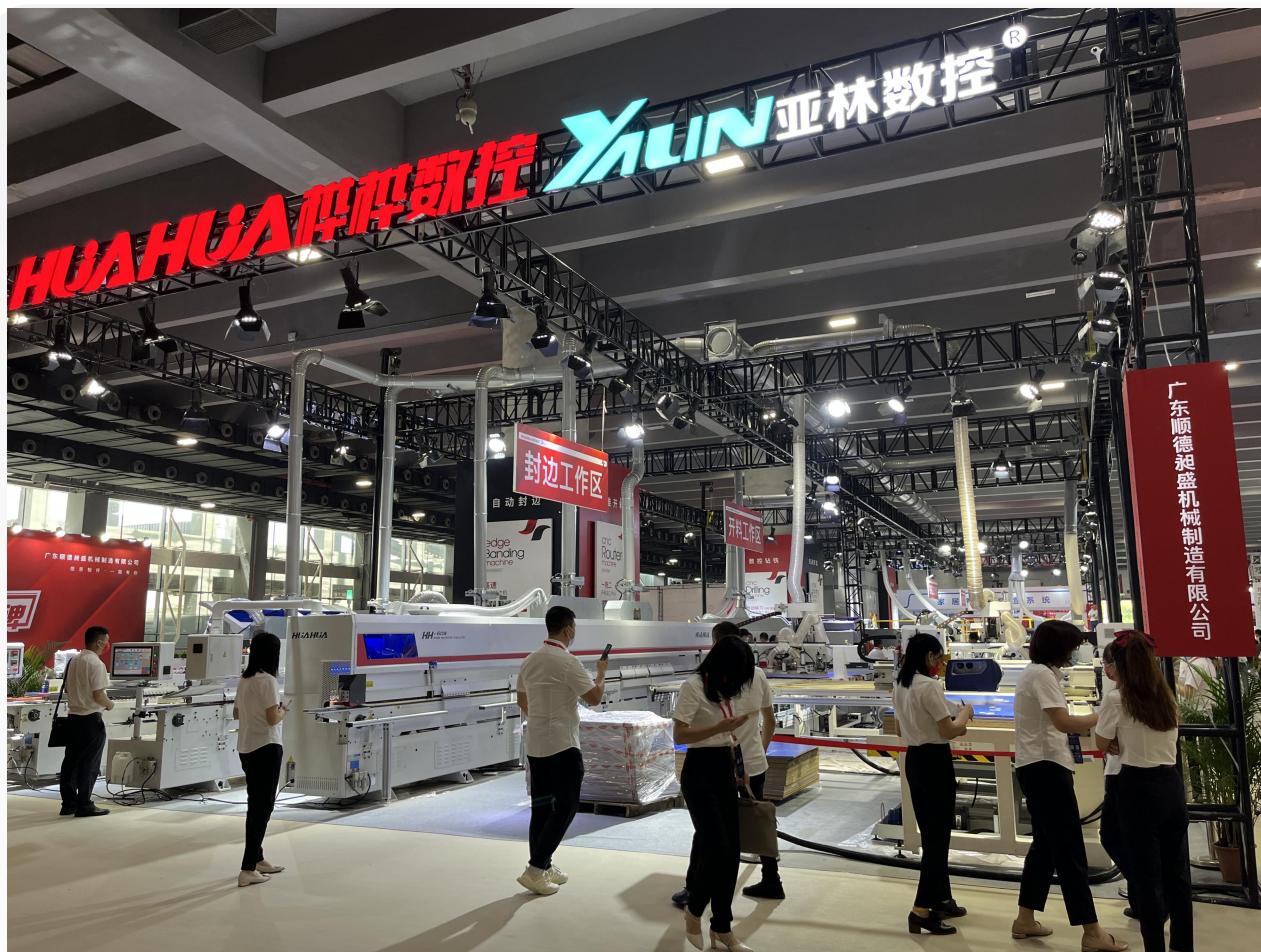

SERVICE SYSTEM  
EXHIBITION

HUAHUA 桦桦数控®



SERVICE SYSTEM  
EXHIBITION

HUAHUA 桦桦数控®

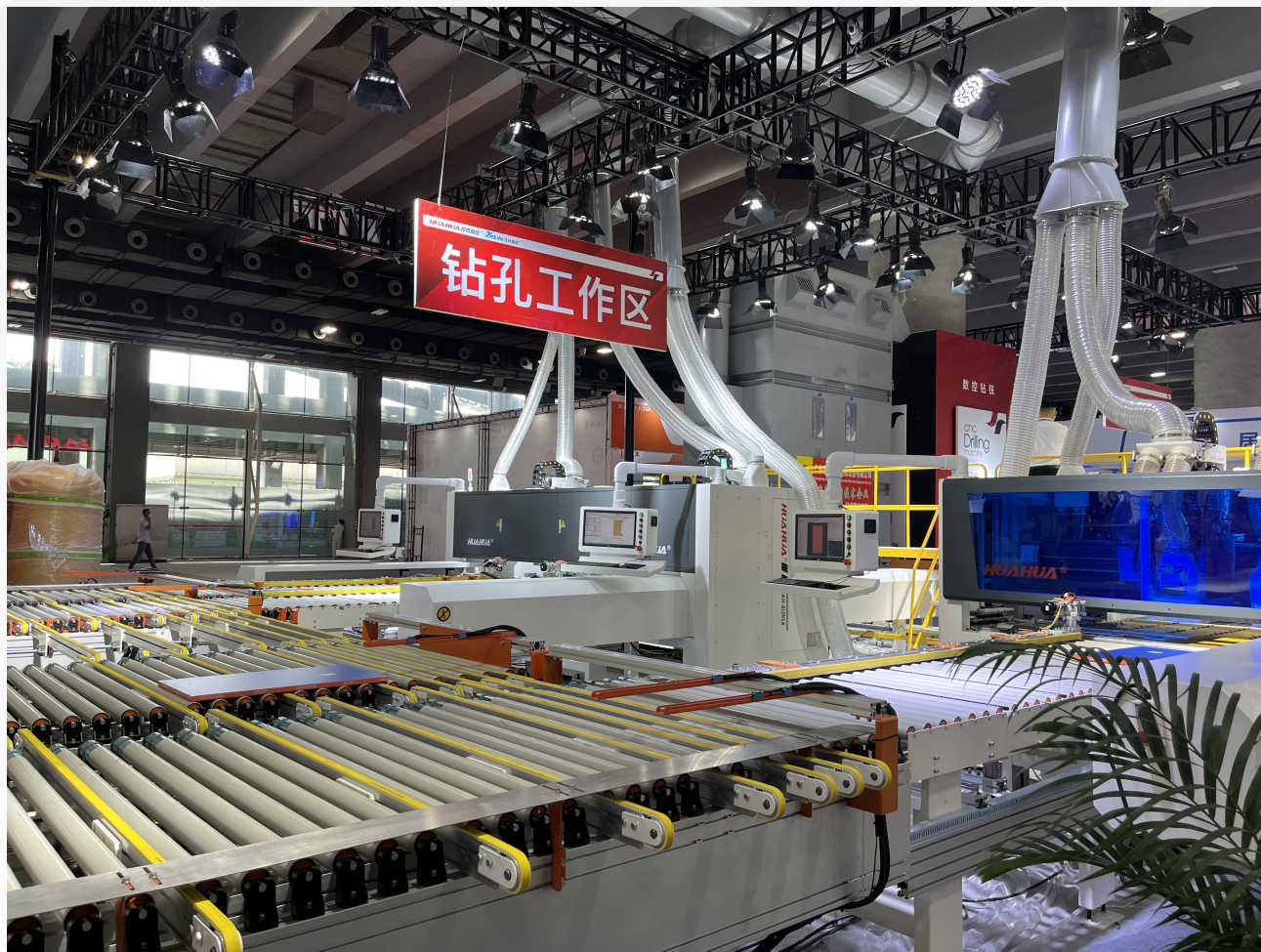

SERVICE SYSTEM  
EXHIBITION

HUAHUA 桦桦数控®



Pre-sales service

Provide information  
Consulting information



Provide customers with relevant information, as well as equipment consultation, product design, machine demonstration and other services; before the equipment is installed, the user's technical staff can arrange 2 people to come to our company for free training

Market research  
Product customization



Carry out market research and forecast in advance to provide customers with solutions and product services; accept product customization, professional technical team to discuss and evaluate, and meet customer needs according to the situation.

Planning production  
ensuring quality



From the whole to the details, from the appearance to the internal parts, from the single machine to the flexible connection, standard mode production; ensure the quality of the equipment, reduce the labor for customers, improve the site utilization and production efficiency



AFTER  
SALES  
SERVICE

24 Hours Online  
Service



1. Available Engineers Go To Factory Install Machine
2. 24 Hour Online Service
3. Remote Support

Regular Training  
Meetings to Dealers



1. New Product Training
2. Collect Market Feedback and Suggestion

Forever After-sale  
Technical Service

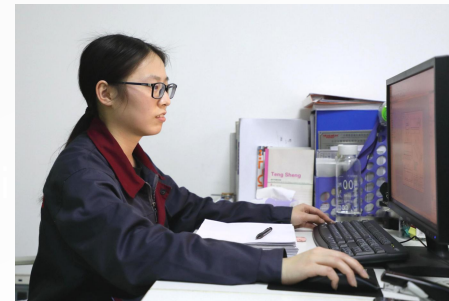

1. Provide Permanent After-sales Service and Spare Parts Replacement.